

# WENGUE EcoDesign

# KUNST



## MAßE

MAßE H x B x T	551x646x476 mm
GEWICHT BRUTTO	115 kg
MAßE FEUERRAUMTÜR	450x277 mm
DURCHMESSER DES ABGASSTUTZEN	Ø 150-153 mm Vertikal
ABSTAND ZU ANGRENZENDEN BRENNBAREN MATERIALIEN:	
Seitlich	30 cm
Vorne	100 cm
Hinten	10 cm

## EIGENSCHAFTEN

ROST AUS GUSSEISEN	
NENNLEISTUNG	6,7 KW
WIRKUNGSGRAD	80,7 %
CO - EMISSIONEN	0,10 %
HITZESCHUTZANSTRICH	800°C
GLASKERAMIKSCHEIBE HITZEBESTÄNDIG BIS	750°C

EAN 8426964230307  
REF. KUNST 23030

## ECODESIGN



EXTERNE  
LUFTZUFUHR



DOPPELBLECHGEHÄUSE  
6 + 3 MM



VERMICULIT  
AUSKLEIDUNG



BEDRUCKTE  
GLASKERAMIK



SCHEITLÄNGE 50 CM



RAUMHEIZVERMÖGEN



SCHEIBENSPÜLUNG



DREIFACHVERBRENNUNG

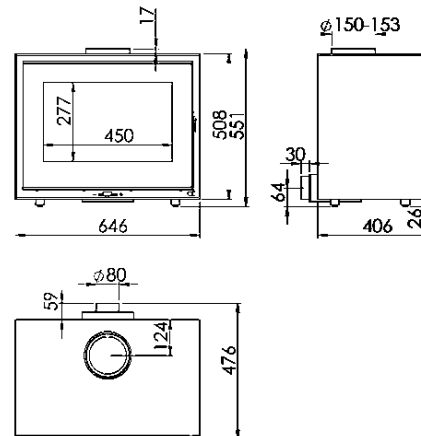

WENGUE DE



**BImSchV2**

**Art. 15a B-VG**

